



**Bid Specifications:**

The Mini Heated Merchandising Cabinet shall be Merco model \_\_\_\_\_ rated at 1420 watts, 120 volts, single phase AC.

Mini Heated Merchandising Cabinet

# Mini Heated Merchandising Cabinet

## Model

- HMC-M1
- HMC-M1X
- HMC-M2
- HMC-M2X



## Standard Features

- Rounded Euro designed cabinet features tempered glass sides and door for full-view display
- Shatter-resistant fluorescent light enhances food appeal while safe-guarding food products from bulb breakage
- Single or Dual-sided door models
- Accommodates half-size sheet pans
- Doors are reversible

## Options

- Food decals and merchandising signs are available to help promote product
- Various rack configurations available
- 4" (102 mm) Adjustable Legs

## Description

The Merco Mini Heated Merchandising Cabinet is a profitable way to create impulse food sales. Controlled moisturized heat lets you display and hold hot foods longer using minimum counter space.

### Flexibility

The Merco Mini Heated Merchandising Cabinet has separate heat and humidity controls to keep crisp foods crisp and moist foods moist, not just for minutes but for hours. It holds everything from hot pretzels to 15" (381 mm) pizza, croissants to bagels, and even hot dogs and meat pies.

Electrical components, controls, and water reservoir are located at the top for easy access. Electronic controls monitor cabinet temperature. Models with two doors are available for pass-through convenience.

The Merco Mini Heated Merchandising Cabinet is ideal for restaurants, pizzerias, convenience stores, concession stands, snack bars, and kiosks.

### Voltage

120 volts, 60 Hz, 1420 watts, 11 amps standard; uses NEMA 5-15P.

### Merco Guarantee:

Merco equipment is guaranteed to be free from quality problems in materials and workmanship for a period of one (1) year from the date of purchase, or eighteen (18) months from the date of shipment from factory, whichever comes first. Metal sheath air heating elements are warranted against burnout and breakage for two (2) years..



Models

- HMC-M1
- HMC-M1X
- HMC-M2
- HMC-M2X

1111 N. Hadley Rd.  
P.O. Box 1229  
Ft. Wayne, IN 46801-1229

Tel: 888-417-5462  
Fax: 800.285.9511

[www.mercoproducts.com](http://www.mercoproducts.com)



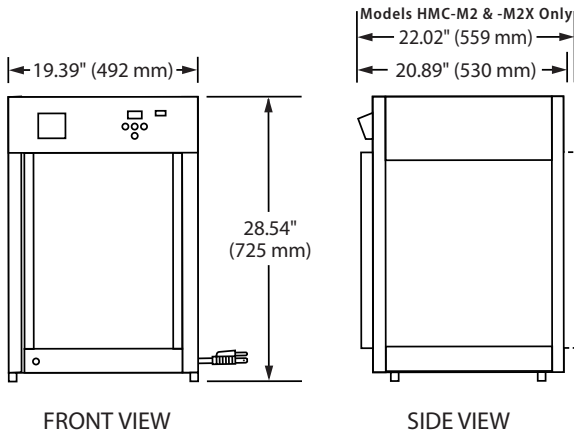

### Dimensions

**HMC-M1 & HMC-M1X:**  
19.39" W x 20.89" D x 28.54" H (492 x 530 x 725 mm)

**HMC-M2 & HMC-M2X:**  
19.39" W x 22.02" D x 28.54" H (492 x 559 x 725 mm)

**Cabinet Opening:**  
15.75" W x 19.75" H (400 x 502 mm)

### Accessories

- 4-Tier Circle Rack (Requires motorless rack coupling on -X models)
- 4-Shelf Multi-Purpose Rack- Each shelf 13.63"W x 12.62 D (346 x 321 mm)
- 4-Shelf Angel Rack - Each shelf 14.19"W x 14.63"D (360 x 370 mm)
- 3-Tier Pretzel Tree (Requires motorless rack coupling on -X models)
- Motorless Rack Coupling (For -X models only)
- Graphic Adhesive Decals (three (3) per set)
  - Hot Fresh Pizza
  - Hot Fresh Sandwiches
  - Hot Fresh Pretzels
  - Hot & Fresh



### Water Quality Requirements

Water supply in excess of 3.0 grains of hardness per gallon (GPG) (.75 grains of hardness per liter) must be treated and softened before being used. Water containing over 3.0 GPG (.75 GPL) will decrease the efficiency and reduce the operating life of the unit. *NOTE: Product failure caused by liming or sediment build-up is not covered under warranty.*

### Cord Location

Facing controls, right-hand side panel, lower right corner.

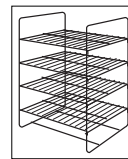
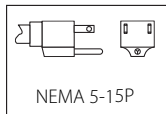

**4-Tier Multi-Purpose Rack**  
Rack Opening: 3.5" (89mm)

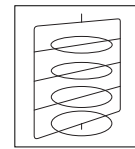

**4-Tier Pizza Rack**  
Rack Opening: 3.25" (83mm)  
Maximum 15" (381 mm) diameter pans

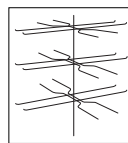

**3-Tier Pretzel Tree**  
Rack Opening: 5.88" (149mm)

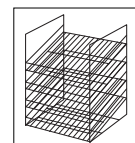

**4-Shelf Angle Rack**  
Rack Opening: 3.7" (95mm)

Model	Type	Description	Shipping Weight
HMC-M1	1-Door	1-Door Mini Heated Merchandising Cabinet - Includes one (1) rack and one (1) graphic sign	90 lbs. (41 kg)
HMC-M1X	1-Door	1-Door Mini Heated Merchandising Cabinet - Includes one (1) rack and one (1) graphic sign	90 lbs. (41 kg)
HMC-M2	2-Door	2-Door Mini Heated Merchandising Cabinet - Includes one (1) rack and one (1) graphic sign	91 lbs. (41 kg)
HMC-M2X	2-Door	2-Door Mini Heated Merchandising Cabinet - Includes one (1) rack and one (1) graphic sign	91 lbs. (41 kg)

Designs and specifications subject to change without notice.

### Models

- HMC-M1
- HMC-M1X
- HMC-M2
- HMC-M2X